

DUCA®

TRE3 S/M/L PORTFOLIO



TECHNICAL DATA SHEET

TRE3 Series



Application

For domestic hot water system such as mix water underfloor heating system, air energy hot water circulation system, solar hot water circulation system and family hot, cold water pressurization circulation, etc.

Main Features

- Maximum efficiency $EEl \leq 0.20$
- Compact design, small size, and light weight
- Low noise, high sealing
- Proportional pressure mode
- Constant pressure mode
- Constant speed mode
- AUTO adapt mode

Working Conditions

- Liquid Temperature: $2^{\circ} \sim 95^{\circ}$
- Ambient Temperature: $0 \sim 40^{\circ}$
- Maximum System Pressure : 10bar
- Protection Level : IP44
- Nominal Voltage/Frequency : 220V~240V/50~60Hz
- Insulation Class : F
- Inrush Current: <2A
- Pumped Liquid Properties: clean liquid, free of solids and mineral oils, non-toxic, chemically neutral, similar to water properties

$EEl \leq 0.20$

iPWM

ErP
READY

CE RoHS
Compliant

MADE IN
TURKIYE

PANORAMIC PRODUCT OVERVIEW

TRE3 Series



TRE3S

Versions	Max Flow Rate	Max. Head
15-65-130	2.5 m ³ /h	6.5m
25-65-130	2.5 m ³ /h	6.5m
25-65-180	2.5 m ³ /h	6.5m
32-65-180	2.5 m ³ /h	6.5m

TRE3M

Versions	Max Flow Rate	Max. Head
15-40-130	2.5 m ³ /h	4m
25-40-130	2.5 m ³ /h	4m
15-60-130	3.2 m ³ /h	6m
25-60-130	3.2 m ³ /h	6m
25-60-180	3.2 m ³ /h	6m
32-60-180	3.2 m ³ /h	6m
15-80-130	3.5 m ³ /h	8m
25-80-130	3.5 m ³ /h	8m
25-80-180	3.5 m ³ /h	8m
32-80-180	3.5 m ³ /h	8m

TRE3L

Versions	Max Flow Rate	Max. Head
15-95-130	4.5 m ³ /h	9m
25-95-180	4.5 m ³ /h	9m
32-95-180	4.5 m ³ /h	9m



TRE3S XX-65

Nameplate



Max. Flow Rate
2.5 m³/h

Max. Head
6.5m

*Custom OEM Nameplate Design
Available Upon Request

Performance Curve

Dimension

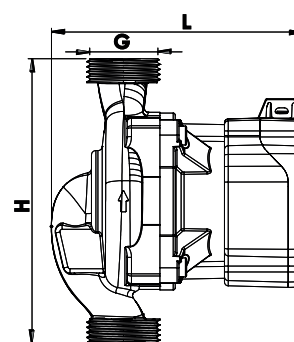
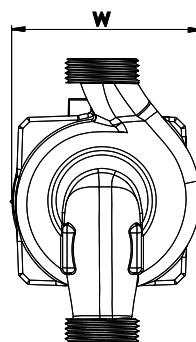
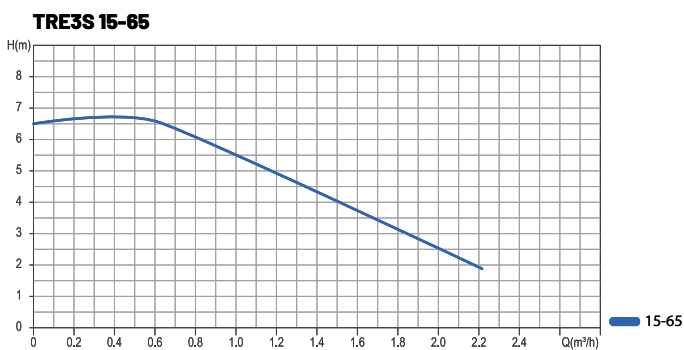

EEI ≤ 0.20



W 94 mm

L 132 mm

H 130 mm

G 1"

Model Information

Model	Min/Max Temp (°C)	L (mm) H2	DN G	P1 Max	Voltage (V)	Rated Current (A)	Union
15-65-130	+2 to +95	130	15mm G1	54W	1x230	0,45	G1 to G3/4
25-65-130	+2 to +95	130	25mm G1½				G1½ to G1
25-65-180	+2 to +95	180	25mm G1½				G1½ to G1
32-65-180	+2 to +95	180	32mm G2				G2 to G1¼

Protective Functions

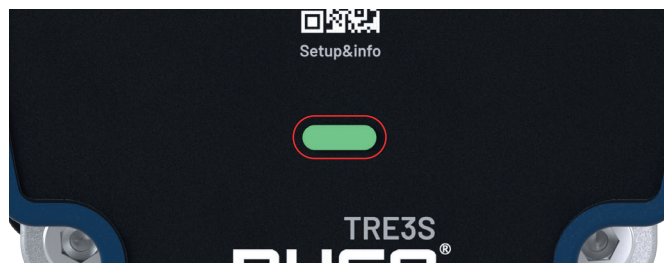

Function Name	Function Description
Blocking Protection	In case of a rotor stuck situation, the pump driver board will enter the "Blocking protection" error state, stop for 1 second and start again. In case of this error condition, a disqualification time of 12 seconds is activated. If 5 or more "blocking protection" error conditions are detected during this disqualification time, the green led will turn off and the red led will flash every 200ms. In addition, each time a "blocking protection" error condition occurs, the 12-second disqualification time is reset and starts over.
Phase Protection	If the motor phase connections are not connected or are damaged, the "Phase Protection" fault condition will be activated on the pump driver board, it will stop for 1 second and start again. In case of this error condition, a disqualification time of 12 seconds is activated. If 5 or more "Phase Protection" error conditions are detected during this disqualification time, the green led will turn off and the red led will flash every 1000ms. In addition, each time a "Phase Protection" error condition occurs, the 12-second disqualification time is reset and starts over.
Over current protection	If an excessive current passes through the motor phase connections, the pump driver card will enter the "Over Current Protection" fault state, stop for 1 second and start again. In case of this error condition, a disqualification time of 12 seconds is activated. If 5 or more "Over Current Protection" error conditions are detected during this disqualification time, the green led will turn off and the red led will flash every 2000ms. In addition, each time a "Over Current Protection" error condition occurs, the 12-second disqualification time is reset and starts over.
Over voltage / Under voltage protection	If the input voltage of the pump driver board goes below 160Vac or above 270Vac, the pump driver board enters the "Overvoltage / Under voltage protection" error state and stops the motor. In the event of this error condition, the green led goes out directly and the red led starts to light continuously without waiting for any repetition. If the error condition disappears, the pump is restarted after 1 second. If the error condition does not repeat, the green led lights up continuously after 12 seconds and the red led goes out.

The pump driver board consists of two different LEDs, red and green. These LEDs provide information about operating mode, error conditions. The table below shows the status of the LEDs according to their lighting combination. Also all LEDs blinking three times each time the pump driver board is initialized. In addition, if there are no error or mode changes, the LEDs go out after one minute.

Status	Green Led	Red Led	Red Led Blink Time	Disqualification Time
Run Mode	On	Off	Always	-
Blocking Protection	Off	On	Every 200ms	12 sec
Phase Protection	Off	On	Every 1000ms	12 sec
Over Current Protection	Off	On	Every 2000ms	12 sec
Over voltage / Under voltage Protection	Off	On	Always	12 sec

LEDs status descriptions

Cable Connection

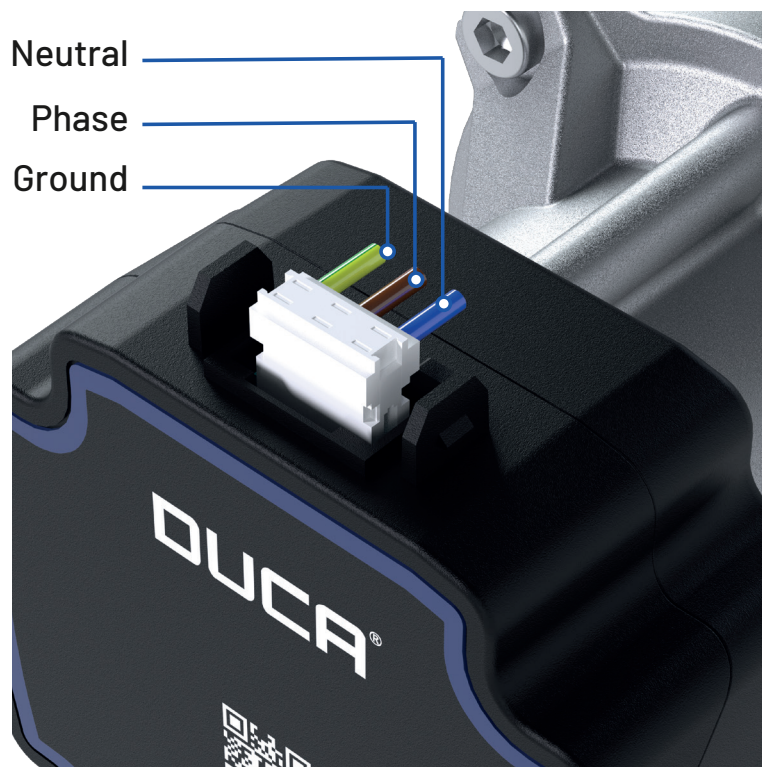

Power Cable

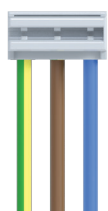

RAST2.5 Pro



Water and dust
resistant cover



TRE3M XX-40

Nameplate



*Custom OEM Nameplate Design
Available Upon Request

Max. Flow Rate
2.5 m³/h

Max. Head
4m

Performance Curve

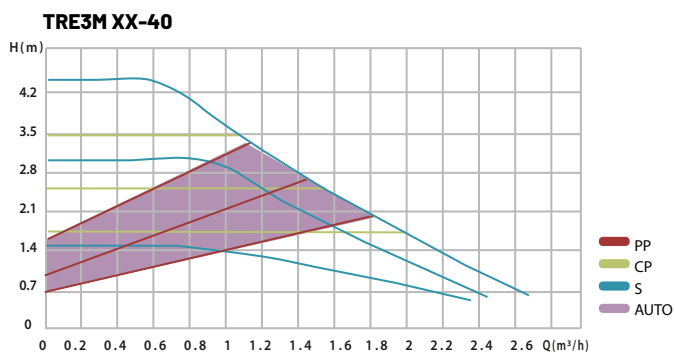

Dimension

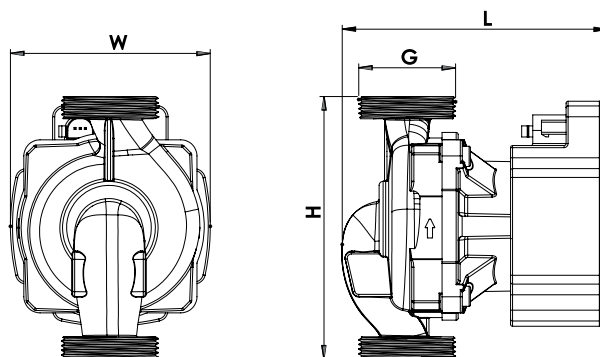

W 99 mm

L 130 mm

H 130mm

G 1 1/2"

EEI ≤ 0.20

iPWM



Model Information

Model	Min/Max Temp (°C)	L (mm) H2	DN G	P1 Max	Voltage (V)	Rated Current (A)	Union
15-40-130	+2 to +95	130	15mm G1	40W	1x230	0,37	G1 to G3/4
25-40-130	+2 to +95	130	25mm G1 1/2				G1 1/2 to G1



TRE3M XX-60

Nameplate



*Custom OEM Nameplate Design
Available Upon Request

Max. Flow Rate
3.2 m³/h

Max. Head
6m

Performance Curve

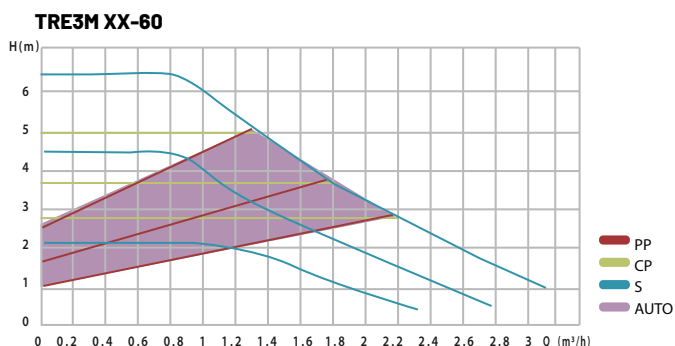

Dimension

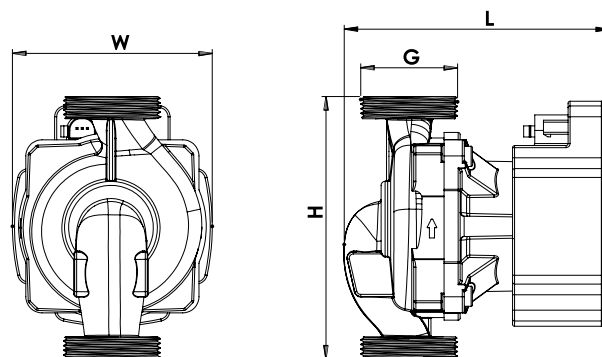

W 99 mm

L 130 mm

H 130mm

G 1 1/2"

EEI ≤ 0.20

iPWM

ErP
READY

CE **RoHS**
Compliant

Model Information

Model	Min/Max Temp (°C)	L (mm) H ₂	DN G	P1 Max	Voltage (V)	Rated Current (A)	Union
15-60-130	+2 to +95	130	15mm G1	50W	1x230	0,45	G1 to G3/4
25-60-130	+2 to +95	130	25mm G1½				G1½ to G1
25-60-180	+2 to +95	180	25mm G1½				G1½ to G1
32-60-180	+2 to +95	180	32mm G2				G2 to G1¼



TRE3M XX-80

Nameplate



*Custom OEM Nameplate Design
Available Upon Request

Max. Flow Rate
3.5 m³/h

Max. Head
8m

Performance Curve

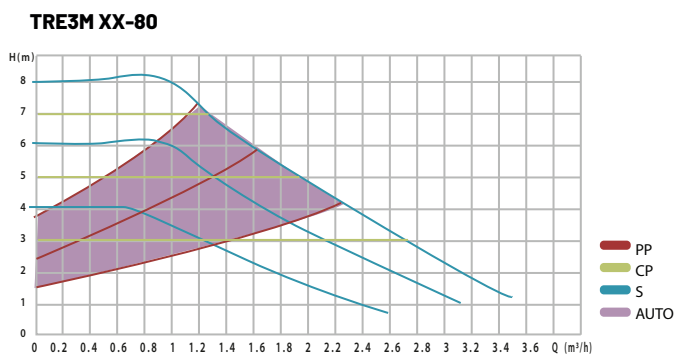

Dimension

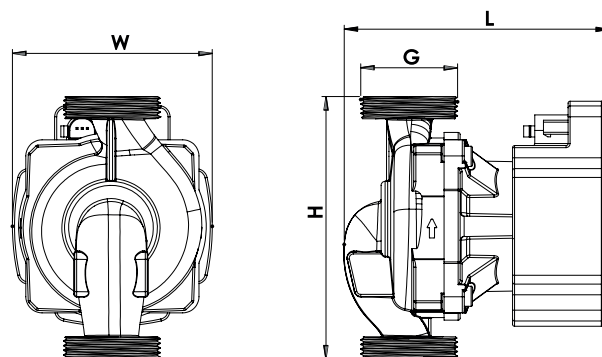

W 99 mm

L 130 mm

H 130mm

G 1 1/2"

EEI ≤ 0.20

iPWM

ErP
READY

CE RoHS
Compliant

Model Information

Model	Min/Max Temp (°C)	L (mm) H2	DN G	P1 Max	Voltage (V)	Rated Current (A)	Union
15-80-130	+2 to +95	130	15mm G1	50W	1x230	0,45	G1 to G3/4
25-80-130	+2 to +95	130	25mm G1½				G1½ to G1
25-80-180	+2 to +95	180	25mm G1½				G1½ to G1
32-80-180	+2 to +95	180	32mm G2				G2 to G1¼

PWM Mode

Pump driver board have been working in a two control modes that PWM and gear mode. In PWM mode pump speed change as a function of PWM input profile. When there is no PWM signal, pump driver board have been working in a gear mode. In gear mode, pump runs in five different speed. On the other hand pump driver board has a five LEDs for give information about operation status and error conditions.

Pump driver board has a two PWM signal that input PWM signal and output PWM. Input PWM signal works in 1 - 4 kHz range and changes the pump speed. Output PWM signal work as a feedback signal and it is fixed at 75 Hz. Output PWM give a information about the pump output power.

Optocoupler Isolation	AVAILABLE
PWM Output Frequency	75 Hz
PWM Input Frequency	1 - 4 kHz
Input voltage high level U_{IH}	4.0 - 24V
Input voltage low level U_{IL}	< 1V
High level input current I_H	3.5 mA - 10 mA
PWM adjustable range	0 - 100 %
Signal polarity	Fixed
Signal line length	< 3m
Rise and fall time	< T/1000

Table 2. PWM signal characteristics

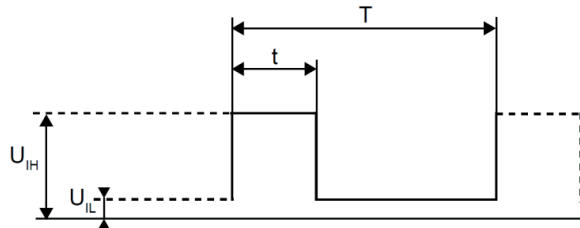

Figure 3. PWM signal characteristics waveform

PWM Interface

The PWM interface consists of an electronic part that connects the external control signal in isolation to the microcontroller of the pump driver board. In addition, the interface allows the user to avoid contact with hazardous voltage if the signal touches the wires when power is connected to the pump.

Position	Description
1	Galvanic Isolation
2	PWM Output
3	ISO GND
4	PWM Input

Table 3. Interface schematic description

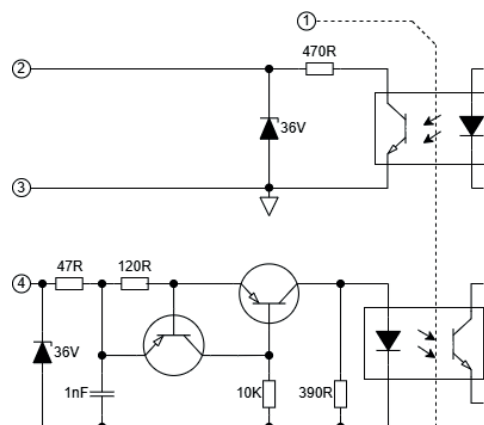

PWM Input Signal Profile

PWM mode operating principle is given in the picture below. In PWM Mode, the pump can be driven at different speeds. When the PWM signal duty cycle value is low, circulating pump rotate high speed because if the PWM connection is damaged the circulating pump must be run at maximum speed to transfer heat from primary heat exchanger. With the help of hysteresis, the pump can be prevented from switching off and on continuously at low speeds.

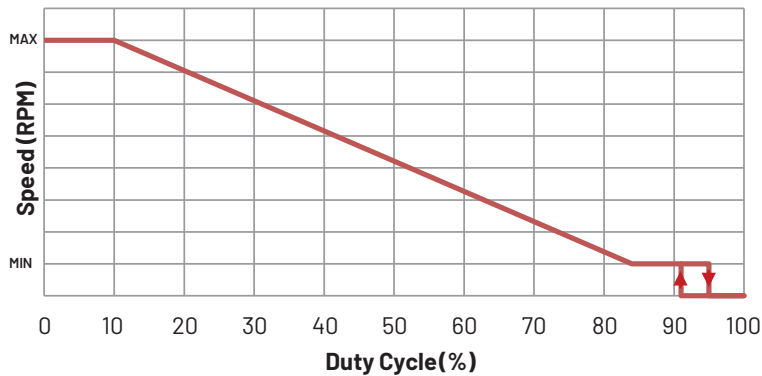

Figure 5. Input PWM waveform

Input PWM Duty Cycle (%)	Pump Driver Board Status
0	There is no PWM signal send to the pump driver board. So in this status pump driver have been work on a gear mode.
0 < Duty ≤ 10	Pump runs in maximum speed.
10 < PWM ≤ 84	Pump speed is linearly drops from the maximum speed to minimum speed.
84 < PWM ≤ 91	Pump runs in minimum speed.
91 < PWM < 95	In this range, hysteresis is used to stop the pump above 95 and drive it at minimum speed when it falls below 91 .
95 ≤ PWM ≤ 100	Pump stops running, Standby

Table 4. Input PWM description

PWM Output Signal Profile

The PWM output signal offers information below that about pump driver board.

- Current power consumption
- Warning
- Alarm
- Operating status

Position	Value	Description
X Axis	-	Output power consumption (W)
Y Axis	-	PWM output signal percentage (%)
A	%95	Standby, Pump stop
B	%90	Alarm Stop : Blocked pump
C	%85	Alarm Stop : Electric fault
D	%75	Warning
E	%0-%70	Slope: 1% / watt PWM signal
F	%70	Saturation at 70 W

Table 5. Output PWM description

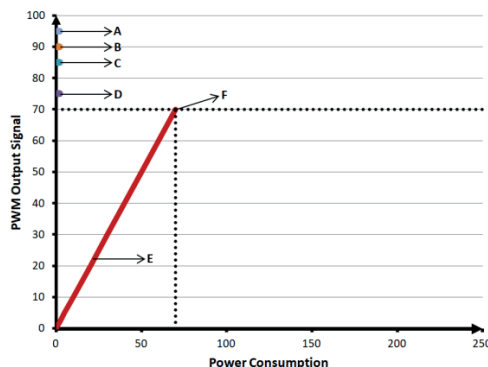

Figure 6. Output PWM Waveform

Gear Mode

Gear mode is activated if there is no PWM signal. The gear mode operates the pump via the external button with five different output powers as given in the table below.

Gear Mode	Output Power	Output Current
1	35W	0.33A
2	40W	0.37A
3	50W	0.45A
4	55W	0.50A
5	60W	0.55A

Table 6. Gear mode output power and current description

Protective Functions

Function name	Function Description	FAILURE TYPE
Electronic unlock	When the shaft is stuck , the electric pump will start with normal torque first. If it cannot start, it will start twice at 1.2 times the maximum torque. If it cannot start again, it will start twice at 1.5 times the maximum torque. If it cannot start smoothly, Stop and report the pump blockage fault from the PWM feedback line. After 10 minutes, try to start again.	Failure error
Oversvoltage / Undersvoltage protection	In abnormal conditions, when the input voltage is less than 160V or a voltage higher than 270V, the motor will enter the protection state and report an electrical fault to avoid over-range use and cause damage, the voltage is restored, and the electric pump resumes operation.	Failure error
Overcurrent protection	When the electric pump is short-circuited fault occur, the electric pump reports an electrical fault and needs to be powered off and restarted	Lockout error
Phase protection	When the electric pump lacks and equal fault occurs, the electric pump reports an electrical fault and needs to power off and restart.	Lockout error

Table 7. Protective functions

The pump driver board consists of five different LEDs. These LEDs provide information about operating mode, error conditions . The table below shows the status of the LEDs according to their lighting combination. Also all LEDs blinking three times each time the pump driver board is initialized. In addition, if there are no error or mode changes, the LEDs go out after one minute.

Status	LEDs Combination
Gear Mode 1	●●●●●
Gear Mode 2	●●●●●
Gear Mode 3	●●●●●
Gear Mode 4	●●●●●
Gear Mode 5	●●●●●
PWM Mode	●●●●●
Blocking Protection	●●●●●
Phase Protection	●●●●●
Over Current Protection	●●●●●
Oversvoltage / Undersvoltage Protection	●●●●●

Table 8. LEDs status descriptions



Cable Connections

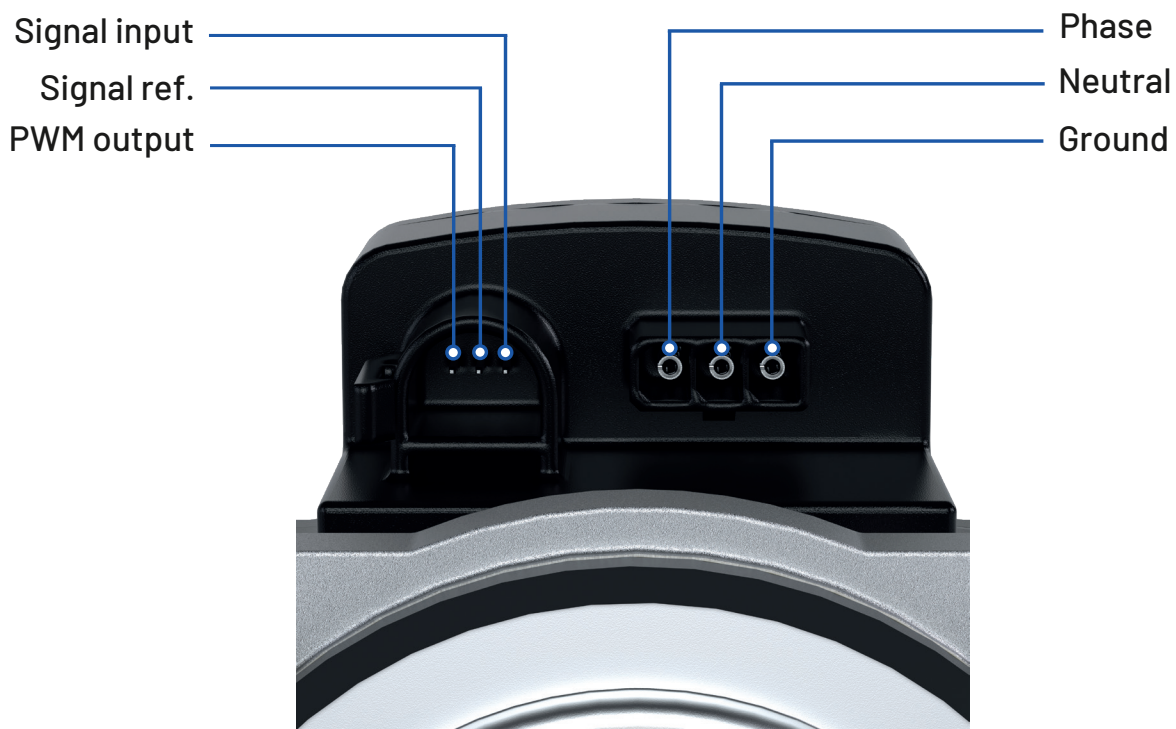

Pwm Cable



FCI

Power Cable

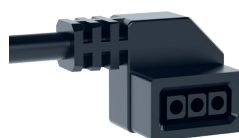

MOLEX 15311032



TRE3L XX-95

Nameplate



*Custom OEM Nameplate Design
Available Upon Request

Max. Flow Rate
4.5 m³/h

Max. Head
9m

Performance Curve

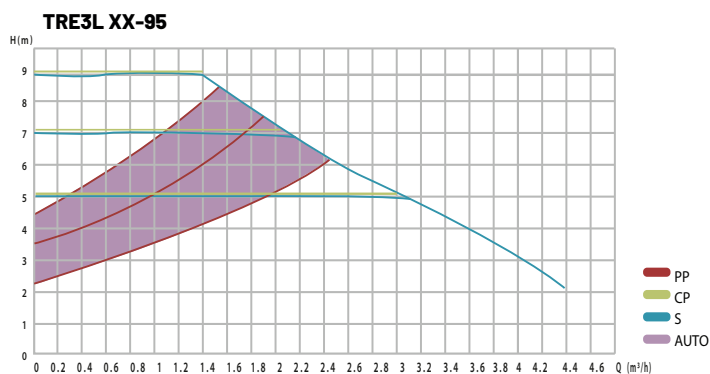

EEI ≤ 0.20

iPWM

ErP
READY

CE RoHS
Compliant

Dimension

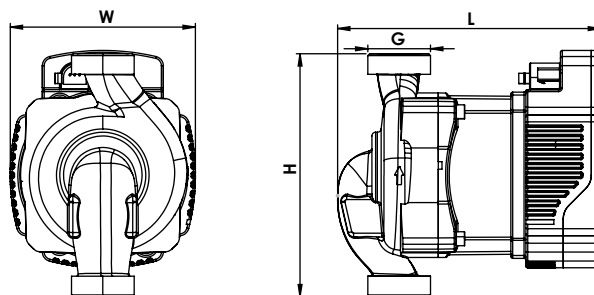

W 99 mm

L 173,2 mm

H 130 mm

G 1 1/2"

Model Information

Model	Min/Max Temp (°C)	L (mm) H2	DN G	P1 Max	Voltage (V)	Rated Current (A)	Union
15-95-130	+2 to +95	130	15mm G1	100W	1x230	0,65	G1 to G3/4
25-95-180	+2 to +95	180	25mm G1½				G1½ to G1
32-95-180	+2 to +95	180	25mm G1½				G1½ to G1

PWM Mode

Pump driver board have been working in a two control modes that PWM and gear mode. In PWM mode pump speed change as a function of PWM input profile. When there is no PWM signal, pump driver board have been working in a gear mode. In gear mode, pump runs in five different speed. On the other hand pump driver board has a five LEDs for give information about operation status and error conditions.

Pump driver board has a two PWM signal that input PWM signal and output PWM. Input PWM signal works in 1 - 4 kHz range and changes the pump speed. Output PWM signal work as a feedback signal and it is fixed at 75 Hz. Output PWM give a information about the pump output power.

Optocoupler Isolation	AVAILABLE
PWM Output Frequency	75 Hz
PWM Input Frequency	1 - 4 kHz
Input voltage high level U_{IH}	4.0 - 24V
Input voltage low level U_{IL}	< 1V
High level input current I_H	3.5 mA - 10 mA
PWM adjustable range	0 - 100 %
Signal polarity	Fixed
Signal line length	< 3m
Rise and fall time	< T/1000

Table 2. PWM signal characteristics

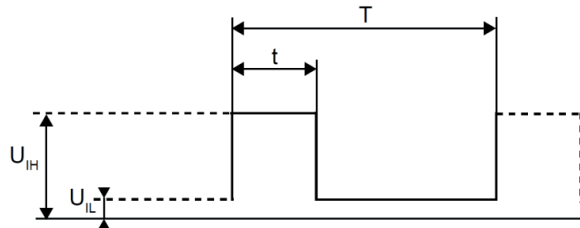

Figure 3. PWM signal characteristics waveform

PWM Interface

The PWM interface consists of an electronic part that connects the external control signal in isolation to the microcontroller of the pump driver board. In addition, the interface allows the user to avoid contact with hazardous voltage if the signal touches the wires when power is connected to the pump.

Position	Description
1	Galvanic Isolation
2	PWM Output
3	ISO GND
4	PWM Input

Table 3. Interface schematic description

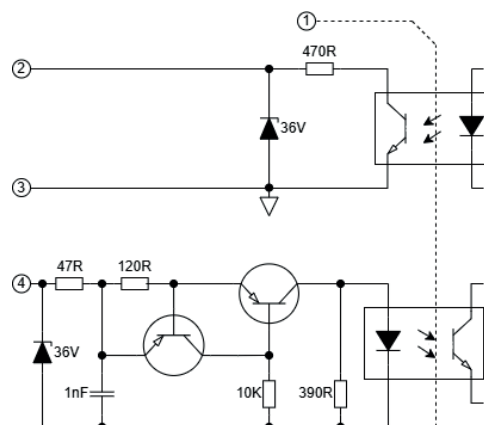

PWM Input Signal Profile

PWM mode operating principle is given in the picture below. In PWM Mode, the pump can be driven at different speeds. When the PWM signal duty cycle value is low, circulating pump rotate high speed because if the PWM connection is damaged the circulating pump must be run at maximum speed to transfer heat from primary heat exchanger. With the help of hysteresis, the pump can be prevented from switching off and on continuously at low speeds.

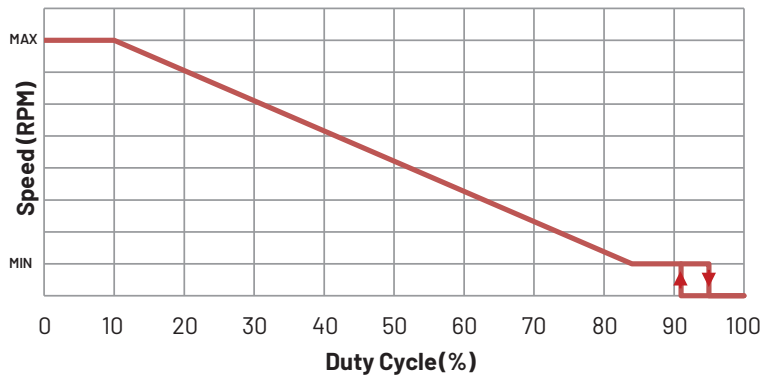

Figure 5. Input PWM waveform

Input PWM Duty Cycle (%)	Pump Driver Board Status
0	There is no PWM signal send to the pump driver board. So in this status pump driver have been work on a gear mode.
0 < Duty ≤ 10	Pump runs in maximum speed.
10 < PWM ≤ 84	Pump speed is linearly drops from the maximum speed to minimum speed.
84 < PWM ≤ 91	Pump runs in minimum speed.
91 < PWM < 95	In this range, hysteresis is used to stop the pump above 95 and drive it at minimum speed when it falls below 91 .
95 ≤ PWM ≤ 100	Pump stops running, Standby

Table 4. Input PWM description

PWM Output Signal Profile

The PWM output signal offers information below that about pump driver board.

- Current power consumption
- Warning
- Alarm
- Operating status

Position	Value	Description
X Axis	-	Output power consumption (W)
Y Axis	-	PWM output signal percentage (%)
A	%95	Standby, Pump stop
B	%90	Alarm Stop : Blocked pump
C	%85	Alarm Stop : Electric fault
D	%75	Warning
E	%0-%70	Slope: 1% / watt PWM signal
F	%70	Saturation at 70 W

Table 5. Output PWM description

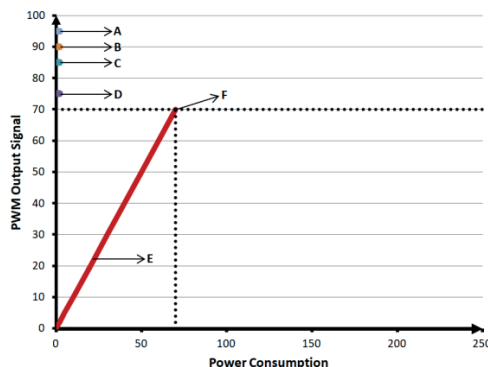

Figure 6. Output PWM Waveform

Gear Mode

Gear mode is activated if there is no PWM signal. The gear mode operates the pump via the external button with five different output powers as given in the table below.

Gear Mode	Output Power	Output Current
1	35W	0.33A
2	40W	0.37A
3	50W	0.45A
4	55W	0.50A
5	60W	0.55A

Table 6. Gear mode output power and current description

Protective Functions

Function name	Function Description	FAILURE TYPE
Electronic unlock	When the shaft is stuck , the electric pump will start with normal torque first. If it cannot start, it will start twice at 1.2 times the maximum torque. If it cannot start again, it will start twice at 1.5 times the maximum torque. If it cannot start smoothly, Stop and report the pump blockage fault from the PWM feedback line. After 10 minutes, try to start again.	Failure error
Oversvoltage / Undersvoltage protection	In abnormal conditions, when the input voltage is less than 160V or a voltage higher than 270V, the motor will enter the protection state and report an electrical fault to avoid over-range use and cause damage, the voltage is restored, and the electric pump resumes operation.	Failure error
Overcurrent protection	When the electric pump is short-circuited fault occur, the electric pump reports an electrical fault and needs to be powered off and restarted	Lockout error
Phase protection	When the electric pump lacks and equal fault occurs, the electric pump reports an electrical fault and needs to power off and restart.	Lockout error

Table 7. Protective functions

The pump driver board consists of five different LEDs. These LEDs provide information about operating mode, error conditions . The table below shows the status of the LEDs according to their lighting combination. Also all LEDs blinking three times each time the pump driver board is initialized. In addition, if there are no error or mode changes, the LEDs go out after one minute.

Status	LEDs Combination
Gear Mode 1	●●●●●
Gear Mode 2	●●●●●
Gear Mode 3	●●●●●
Gear Mode 4	●●●●●
Gear Mode 5	●●●●●
PWM Mode	●●●●●
Blocking Protection	●●●●●
Phase Protection	●●●●●
Over Current Protection	●●●●●
Oversvoltage / Undersvoltage Protection	●●●●●

Table 8. LEDs status descriptions



Cable Connections

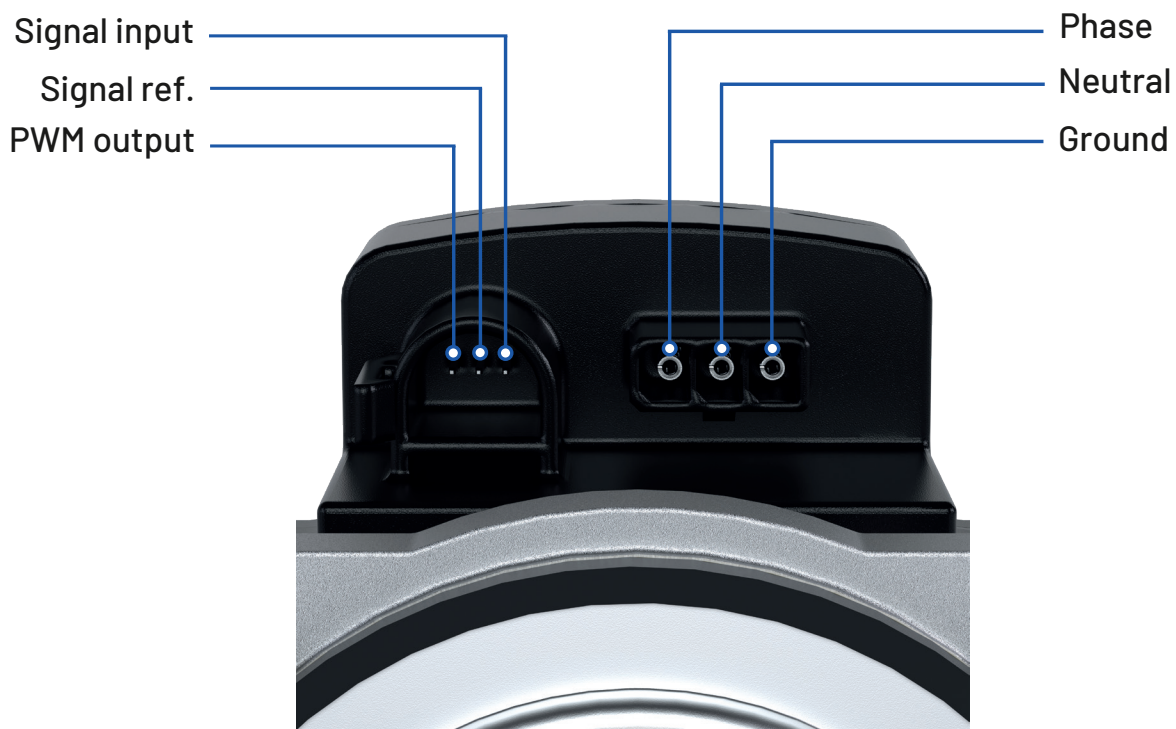

Pwm Cable



FCI

Power Cable

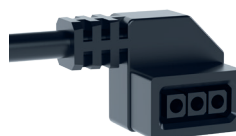

MOLEX 15311032